

Vibratory Screeners

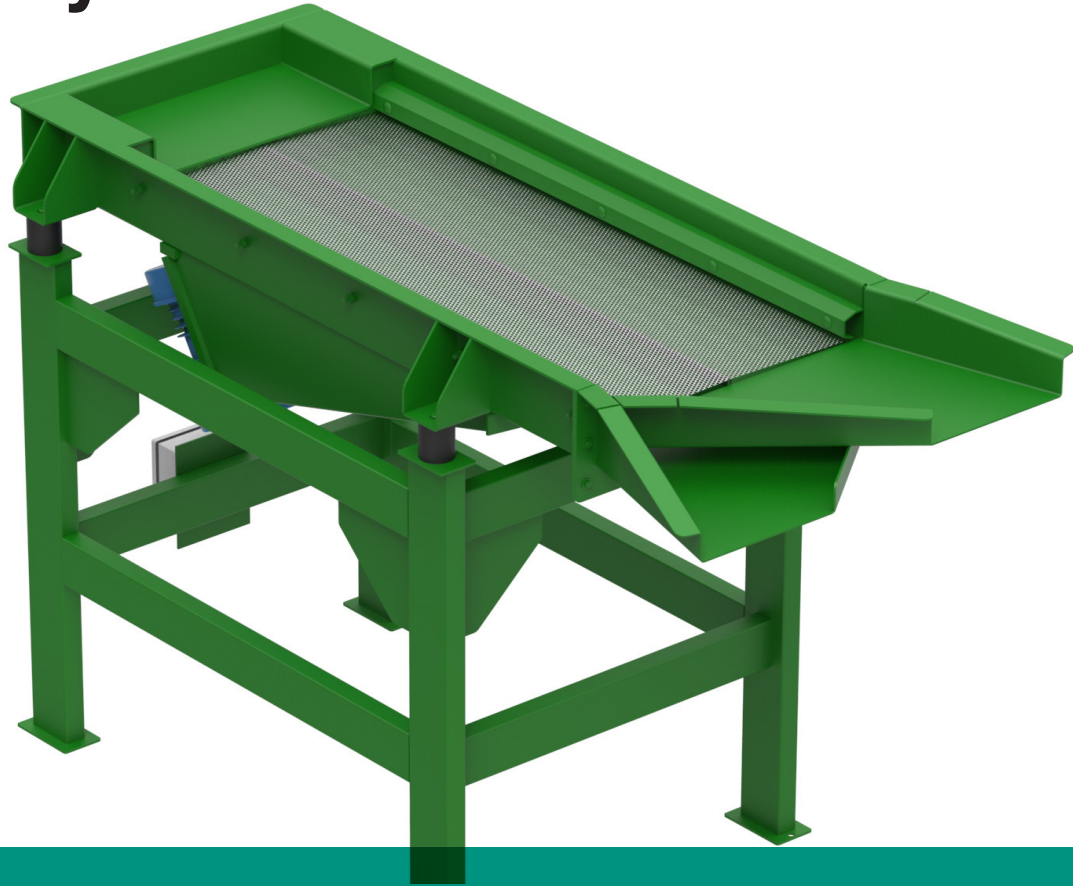

Size, Scalp, Sift & Separate Bulk Materials In Your Process

The Cleveland Vibrator Company offers multiple Vibratory Screener, Scalper and Sieve styles to handle separation and sizing of materials, or removal of unwanted materials from a batch, such as liquids, fines or over-sized product. Our full range of screeners are effective for 20 micron to 4" screen openings, allowing Cleveland Vibrator Co. to be your one stop shop for processing solutions ranging from ultrafine superabrasives and powder metals to plastic regrind and pellets to metal parts or shredded scraps.

BENEFITS INCLUDE

- Flexibility in design options ensure a seamless fit into your existing production processes for your specific vibratory screening applications
- Rated for continuous duty and utilizes 100% screen surface usage
- Vibration designed and tuned for maximum material throughput on screen
- Safety under the most hazardous conditions
- High quality construction, warranty and service

Product Overview

The Cleveland Vibrator Company's **Vibratory Screener Feeder Model** is designed for precise screening where high efficiency is required in the final particle size 100 mesh and larger.

STANDARD DESIGNS

- Impact plate at inlet area for product loading
- (EMS) Below deck, twin dust-tight 1800 RPM Electric Drives including VFD with keypad and E-stop controls package
-or-
- (SF-A) Below deck, single VMSAC Air Piston Vibrator
- Mild steel construction with factory painted finish
- Replaceable screen decks

APPLICATIONS INCLUDE

- Plastics
- Scrap & Recycling
- Mining
- Raw Materials
- Fine Powders
- Chemicals
- Pharmaceuticals
- Powdered Metals
- Super Abrasives
- Food

DISCHARGE OPTIONS

- Standard Flute Chute
- Tapered Chute
- Circular Chute
- Side Discharge



Side-Mount

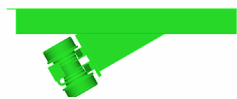

Below-Deck



Above-Deck

EQUIPMENT OPTIONS

- Levelling Gate
- Dust Cover
- Liners
- Impact Plates

OPTIONAL FEATURES

- Circular inlets and outlets
- Right or left-hand outlets
- Above deck or side mounted drives (see left)
- Isolators with support base
- Overhead coil spring suspension mounting
- Dust-tight covers and sight ports
- Booted inlets and outlets for dust containment
- Tension wedges for quick change of screen decks
- Variable Frequency Controls to vary feed rates

ISOLATION OPTIONS

- Air Mounts
- Coil Springs
- Sandwich Rubber
- Marsh-Mellow@Mounts

SPECIAL DESIGNS

For difficult to handle, fluffy, light-density materials or when large screen openings (i.e. larger than 1" square mesh openings) are being used, drives with lower frequency and higher amplitude can be substituted.

For these types of applications, 900 or 1200 RPM drives are available.

Consult our **Sales Department** at **1-800-221-3298** for more details.



Visit The **Cleveland Vibrator Company's YouTube Channel** to see 70+ videos of Vibratory Screener Models in action.

Pick Your Power

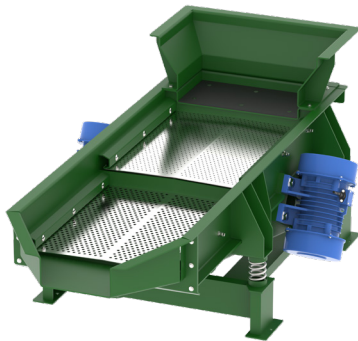

ELECTRIC POWERED

Units which are equipped with twin **Rotary Electric Drives** that are mounted horizontally require no gravitational assistance. Our **EMS Electromechanical Model** is equipped with 1800 RPM vibrators, providing a 0.10" stroke. Force output of the drives can be varied to decrease stroke and reduce final conveying.

Control Options Include:

- Magnetic Starter
- Variable Frequency
- Dynamic Brake

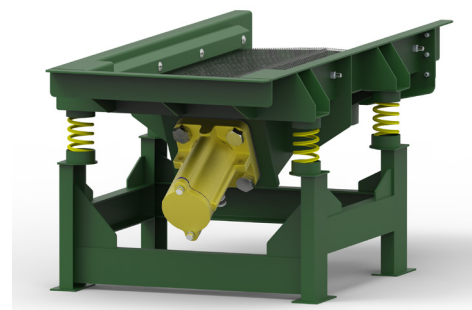

AIR POWERED

SF-A Air Powered Models are fit with double diameter **VMSAC Air Cushioned Piston Vibrators** that guarantees operation at any mounting angle. Rated for continuous duty and safe to use in hazardous areas, exhaust mufflers are supplied on vibrators to significantly reduce noise levels and meet OSHA noise level requirements.

Control Options Include:

- Filter Regulator Lubricator
- Explosion-Proof Solenoid

The Cleveland Vibrator Difference

DESIGNED FOR YOU, YOUR MATERIAL AND YOUR PROCESS

DESIGN EXPERIENCE

The Cleveland Vibrator Team has over 60 years of collective experience sizing and designing vibratory screeners for 100's of materials and applications. So, you know you will get the right force, frequency, amplitude and custom options to make your project successful.

IN-HOUSE TESTING

Cleveland Vibrator's in house testing lab includes an EMS Electromechanical Screener with independent variable frequency and variable amplitude controls to allow determination of optimal vibration conditions for any material AND prediction of feed rates and process outcomes.

HIGH QUALITY, LOW MAINTENANCE

QUALITY COMPONENTS

We use Uras or Cleveland Vibrator Motors, Yaskawa Controls, Firestone isolation mounts, Mettler-Toledo weigh modules, to name a few. We use only the best brands of components, recognized for quality and continuous duty.

LINEAR VIBRATION

Sure, using one motor would cost less. But, most screening applications perform best with linear vibration, that are easily achieved with two synchronized vibrator motors, using the **Dual Motor Principle**, which allows the most control of contact time with the screen. (Refer to the diagram on right)

DESIGN FOR UNIQUE APPLICATIONS

Our Vibratory Screeners are used to separate materials by particle size, remove small amounts of oversized or fine material, or remove excess liquid from finished products. Our selection includes pneumatic & electromagnetically powered units available with single, double or triple decks for materials between 20 microns up to 4 inches.

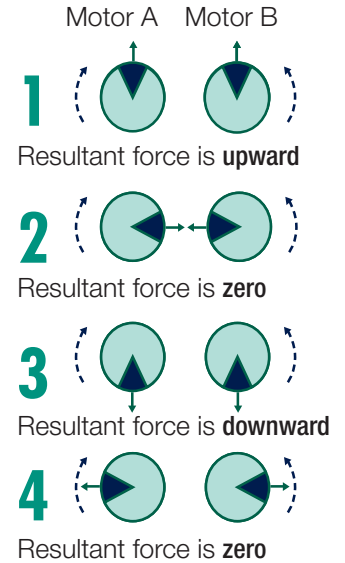

Fine Mesh Screening

HK TECHNOLOGIES

An Affiliate of The Cleveland Vibrator Company

FINE MESH SCREENERS

Used for sizing, fines removal or liquid/solid separation, HK Technologies' Fine Mesh Screening Equipment can handle screening dry or wet materials from 10 micron to #10 mesh. Add Ultrasonics to achieve maximum throughput of materials and increase sieving rates while utilizing 100% of the screen surface.

- Lab & Pilot Sieves
- Production Sifters & Screeners
- Ultrasonic Deblinding Systems
- Rescreening & Remeshing Services

Lab & Pilot Sieves

Fine Mesh Vibratory Sieves for small batch processing & quick sieve analysis of product samples. Get consistent throughput and repeatable sampling compared to manual sieve shaking methods for particle sizing applications.



Production Sifters & Screeners

Fine Mesh Vibratory Sifters & Screeners for large batch processing and continuous screening or scalping applications. Designed to handle difficult-to-screen products and high capacity screening applications.



Ultrasonic Deblinding Systems

Convert your existing gyratory screeners, sieve or sifter to an ultrasonic screener in the matter of minutes, no matter who manufactured it.



Rescreening & Remeshing Services

HK's turn-key remeshing and rescreening services offers a 1-3 day turn around time, providing a quick solution to keep your operations running.



Electromechanical Screeners

The Cleveland Vibrator Company's Model **EMS Electromechanical Screener Feeders** with twin motor drives are designed for precise screening where high efficiency is required in the end particle size. Units are mounted horizontally, requiring no gravitational assistance.

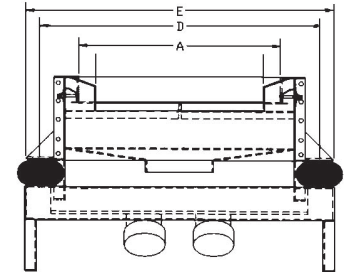
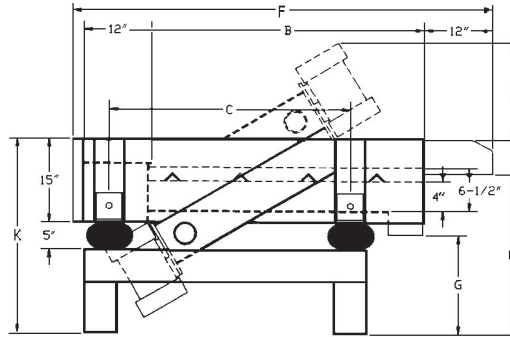

EMS • ELECTROMECHANICAL SCREENER FEEDER

MODEL	A EFFECTIVE SCREEN WIDTH	B EFFECTIVE SCREEN LENGTH	C SUPPORT CENTERS LENGTH	D SUPPORT CENTERS WIDTH	E O.A. WIDTH	F O.A. LENGTH	G FINES DISCHARGE HEIGHT	H OVERS DISCHARGE HEIGHT	J ABOVE DECK HEIGHT	K O.A. HEIGHT	VIBRATORY UNIT REQUIRED (2 EACH)	APPROX. SHIPPING WEIGHT
EMS-1236 RE 9-6	12"	36"	41"	25"	29"	60"	20"	26"	18"	35"	9-6	617 lbs.
EMS-1248 RE 9-6	12"	48"	53"	25"	29"	72"	20"	26"	18"	35"	9-6	723 lbs.
EMS-1260 RE 9-6	12"	60"	65"	25"	29"	84"	20"	26"	18"	35"	9-6	829 lbs.
EMS-1836 RE 9-6	18"	36"	41"	30"	35"	60"	23"	29"	18"	38"	9-6	776 lbs.
EMS-1848 RE 9-6	18"	48"	53"	30"	35"	72"	23"	29"	18"	38"	9-6	1134 lbs.
EMS-1860 RE 9-6	18"	60"	65"	30"	35"	84"	23"	29"	18"	38"	9-6	1093 lbs.
EMS-1872 RE 9-6	18"	72"	77"	30"	35"	96"	23"	29"	18"	38"	9-6	1251 lbs.
EMS-1896 RE 13-6	18"	96"	101"	30"	35"	120"	23"	29"	19"	38"	13-6	1768 lbs.
EMS-18120 RE 13-6	18"	120"	125"	30"	35"	144"	23"	29"	19"	38"	13-6	2086 lbs.
EMS-2448 RE 13-6	24"	48"	53"	37"	42"	72"	23"	29"	19"	42"	13-6	1346 lbs.
EMS-2460 RE 13-6	24"	60"	65"	37"	42"	84"	23"	29"	19"	42"	13-6	1557 lbs.
EMS-2472 RE 13-6	24"	72"	77"	37"	42"	96"	23"	29"	19"	42"	13-6	1768 lbs.
EMS-2496 RE 18-6	24"	96"	101"	37"	42"	120"	23"	29"	21"	42"	18-6	2191 lbs.
EMS-24120 RE 24-6	24"	120"	125"	37"	42"	144"	23"	29"	23"	42"	24-6	2614 lbs.
EMS-3048 RE 13-6	30"	48"	53"	43"	48"	72"	29"	36"	19"	44"	13-6	1346 lbs.
EMS-3060 RE 18-6	30"	60"	65"	43"	48"	84"	29"	36"	21"	44"	18-6	1557 lbs.
EMS-3072 RE 24-6	30"	72"	77"	43"	48"	96"	29"	36"	23"	44"	24-6	1768 lbs.
EMS-3096 RE 24-6	30"	96"	101"	43"	48"	120"	29"	36"	23"	44"	24-6	2191 lbs.
EMS-30120 RE 24-6	30"	120"	125"	43"	48"	144"	29"	36"	23"	44"	24-6	2614 lbs.
EMS-3660 RE 18-6	36"	60"	65"	49"	54"	84"	29"	36"	21"	44"	18-6	2086 lbs.
EMS-3672 RE 18-6	36"	72"	77"	49"	54"	96"	29"	36"	21"	44"	18-6	2403 lbs.
EMS-3696 RE 24-6	36"	96"	101"	49"	54"	120"	29"	36"	23"	44"	24-6	3037 lbs.
EMS-36120 RE 24-6	36"	120"	125"	49"	54"	144"	29"	36"	23"	44"	24-6	3872 lbs.
EMS-4860 RE 24-6	48"	60"	65"	61"	66"	84"	29"	36"	23"	45"	24-6	2614 lbs.
EMS-4872 RE 24-6	48"	72"	77"	61"	66"	96"	29"	36"	23"	45"	24-6	3037 lbs.
EMS-4896 RE 34-6	48"	96"	101"	61"	66"	120"	29"	36"	26"	45"	34-6	4083 lbs.
EMS-48120 RE 34-6	48"	120"	125"	61"	66"	144"	29"	36"	26"	45"	34-6	4929 lbs.

* Have dimensions certified for installations purposes. For more information on sizing, capacity ratings, installation and additional options, call our **Sales Department** at **1-800-221-3298**

Volumetric Vibratory Screeners

Cleveland Vibrator's **RSM Series** features a **Volumetric Vibratory Screener** that is a compact, self-contained unit, incorporating a bulk supply hopper with a vibrator and vibratory screener or scalper. The all in one unit enables production efficiencies for easily dumping material from an inexact process and getting a controlled and uniform product output. Both air (RSM-A) and electric (RSM-E) powered units can be equipped with independent variable controls for adjusting flow rate and vibratory intensity.

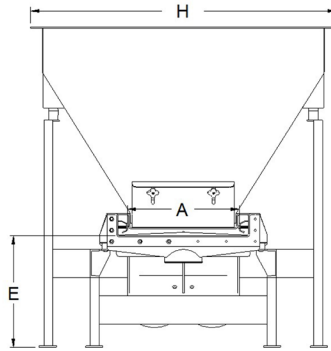
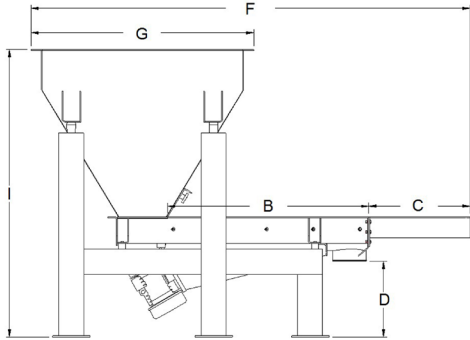

RSM • VOLUMETRIC VIBRATORY SCREENERS

MODEL	A	B	C	D	E	F	G	H	I	HOPPER CAPACITY
RSM-1236	12"	36"	12"	18"	24"	68"	28"	40"	61"	10 ft. ³
RSM-2448	24"	48"	24"	18"	24"	98"	40"	52"	63"	20 ft. ³
RSM-3672	36"	72"	24"	18"	24"	128"	52"	64"	69"	40 ft. ³
RSM-4896	48"	96"	24"	24"	30"	155"	52"	76"	73"	60 ft. ³

Features & Customizable Options:

- Integrated operation controls with digital scale Instruments or timing controls
- Controls for managing flow rate through vibration intensity, force and frequency
- Screener or scalper options for multi-deck configuration, dust control and product contact surface materials are available.

Reduce Plug Blinding

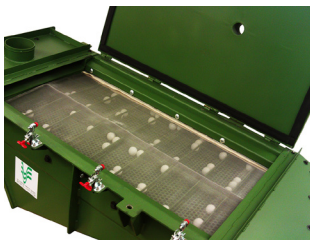

Reduce plug blinding in your process with The Cleveland Vibrator Company's **EMBS Electromechanical Screener fit with customizable Ball Tray Decks**.

Consisting of compartments with a perforated plate bottom, rubber and urethane balls are placed within each compartment. During equipment operation, the balls bounce freely between the screen section and perforated plates, allowing them to strike the underside of the screen surface and randomly knock out the plugged material.

As a result, this added feature keeps your screening process efficient while reducing the cost of downtime necessary to manually clean the screen deck.

Make It Portable



The Cleveland Vibrator Company's Model **PSC-E Portable Sloped Screener** offers assistance for bulk material screening where portability is necessary. It's gravity assisted design ensures maximum product flow using a single Rotary Electric Vibrator Drive.

This model is fully customizable from the ground up. A variety of front wheel options are available to fit any terrain for your application. The Screener is equipped with flat platform plates in the rear for stationary use. Lifting handles on every unit are fit with grips for non-slip guarantee during operation.

Air Powered Screeners

Primarily used in applications where simple, economical control of the feed rate is desirable. Powered by Cleveland Vibrator's VMSAC Air Cushioned Piston Vibrator Series, its efficient and powerful performance is recommended for hazardous-duty areas. Unit comes with a quick acting valve, air line filter, pressure regulator gauge, lubricator, and a 5 ft. air hose with pipe fittings.

Have dimensions certified for installation purposes.

LIGHT-DUTY DIAGRAM

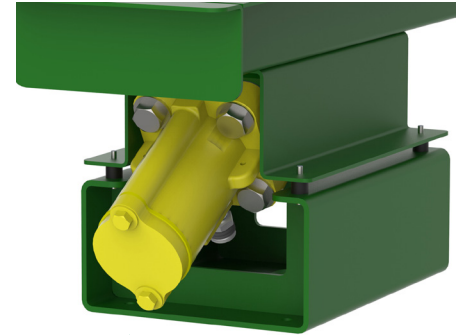
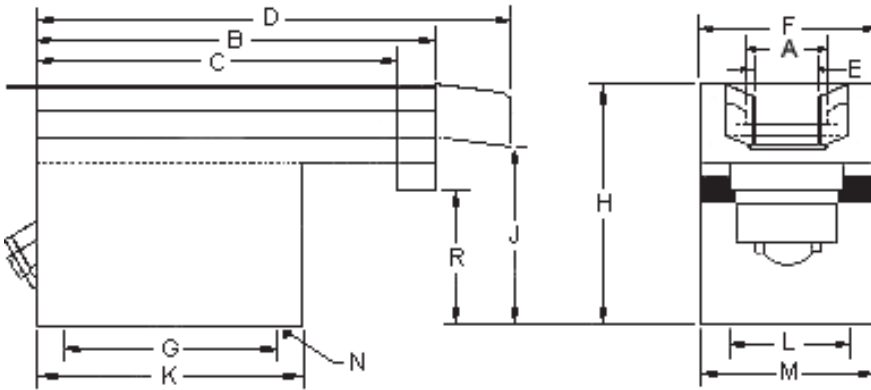

VMSAC
Air Cushioned
Piston Vibrator

SF-A • LIGHT DUTY AIR POWERED SCREENERS

MODEL	A TROUGH WIDTH	B TROUGH LENGTH	C	D	E	F	G	H	J	K	L	M	N	R	VIBRATORY UNIT REQUIRED
SF-A-316-100	3"	16"	14"	18"	2"	6½"	8"	9½"	7"	10"	4"	6¼"	5/8"	6½"	1100 VMSAC
SF-A-420-125	4"	20"	17"	23"	3"	7½"	10"	11½"	8"	12"	4½"	6¾"	7/16"	6¾"	1250 VMSAC
SF-A-624-200	6"	24"	21"	27"	4"	9½"	14"	12½"	9"	16"	5½"	7¾"	7/16"	7¾"	1200 VMSAC
SF-A-830-300	8"	30"	26"	34"	5"	13"	16"	17"	13"	20"	11¾"	11¾"	7/16"	11"	1300 VMSAC

MEDIUM & HEAVY-DUTY DIAGRAM

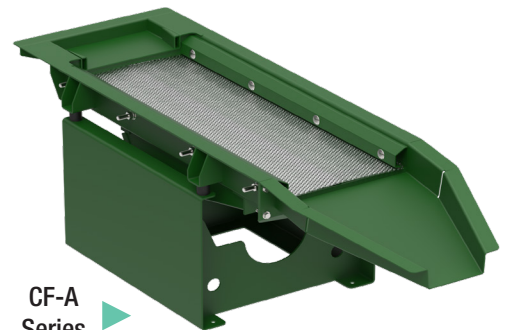
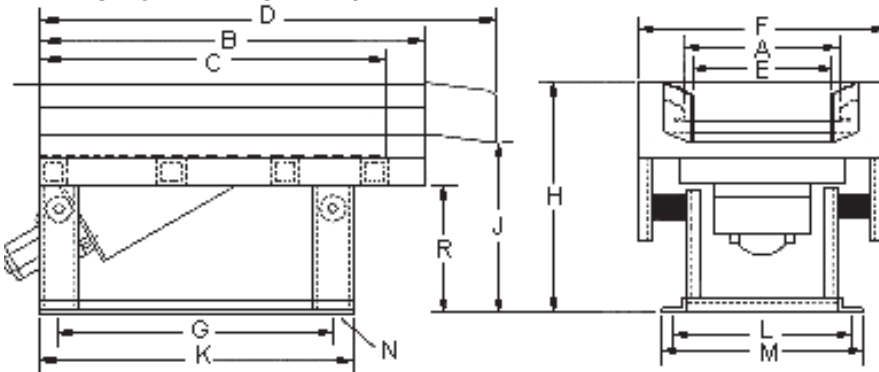

CF-A
Series

SF-A • MEDIUM & HEAVY DUTY AIR POWERED SCREENERS

MODEL	A TROUGH WIDTH	B TROUGH LENGTH	C	D	E	F	G	H	J	K	L	M	N	R	VIBRATORY UNIT REQUIRED
SF-A-1236-350	12"	36"	32"	40"	8"	18¼"	24"	17"	13"	26"	18¼"	20¾"	9/16"	11"	1350 VMSAC
SF-A-1842-400	18"	42"	36"	48"	12"	25¼"	27"	24"	19"	32"	19½"	21½"	9/16"	15"	1400 VMSAC
SF-A-2448-500	24"	48"	42"	54"	16"	31¼"	30"	30"	25"	38"	25½"	27½"	9/16"	21"	1500 VMSAC

Gravity Flow Single Drive Screeners

The Cleveland Vibrator Company's Model **SC-E Gravity Flow Vibratory Screener** is down-sloped 20° for gravity assisted material conveyance. These screeners use a single Rotary Electric Vibrator Drive.

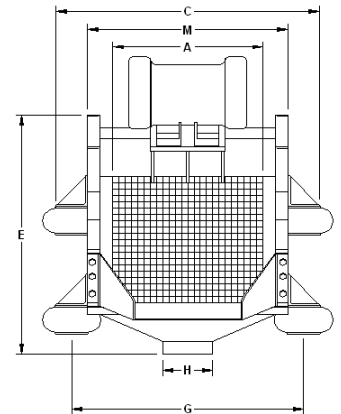
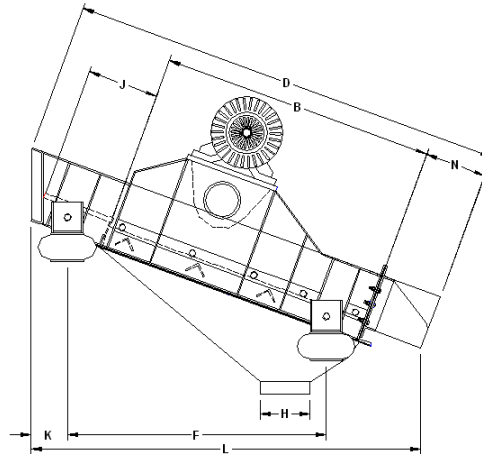

SC-E • GRAVITY FLOW SINGLE DRIVE SCREENER

MODEL	EFFECTIVE SCREEN AREA	A	B	C	D	E	F	G	H	J	K	L	M	N
SC-E-1236	3 ft. ²	12"	36"	31¼"	51½"	23¼"	22½"	27¼"	6"	8"	10"	46¾"	19¼"	6"
SC-E-1848	4½ ft. ²	18"	48"	37¼"	63½"	29"	30"	33¼"	6"	8"	10"	7⅞"	25¼"	6"
SC-E-2448	8 ft. ²	24"	48"	43¼"	63½"	29"	30"	39¼"	6"	8"	10"	7⅞"	31¼"	6"
SC-E-3660	15 ft. ²	36"	60"	59¼"	77½"	37¼"	37½"	53¼"	8"	10"	12½"	70½"	43¼"	6"
SC-E-4872	24 ft. ²	48"	72"	71¼"	93½"	51"	45"	65¼"	12"	12"	15"	85"	55¼"	8"
SC-E-4896	32 ft. ²	48"	96"	71¼"	117½"	62"	52½"	65¼"	12"	12"	15"	107½"	55¼"	8"

* All dimensions are based on an installation angle of 20°. Have your specific dimensions certified for installations purposes by calling our Sales Department at 1-800-221-3298

Other Vibratory Equipment

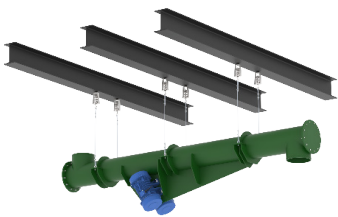

**Model EMF-T
Tube Feeder**

This model provides an enclosed tubular shaped feed tray that allows for materials to feed consistently and effectively without being exposed to external environmental factors.

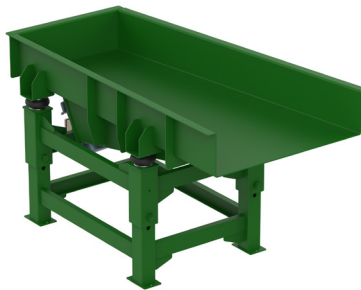

**Model EMF
Electromechanical Feeder**

Utilizing twin (RE) Rotary Electric Vibrator Drives rated for continuous duty, feed your materials using the linear motion that provides smooth, uniform, volumetric flow that is fully adjustable. RE Models available in four speeds for medium to heavy-duty applications.

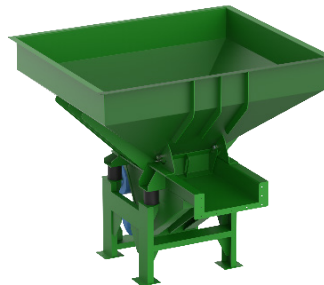

**Model RFM
Volumetric Feeder**

Compact and self-contained units that incorporate a vibratory bulk supply hopper and vibratory feeder enables controlled and reliable flow of bulk materials and parts ensuring efficient and low-cost dumping and feeding into production processes.

VIBRATORY FEEDERS

Typically used to feed raw materials or finished products into mixers, furnaces, production processes or final containers, Cleveland Vibrator's Vibratory Feeders are available in a wide variety of styles and finishes. Fully adjustable volumetric flow allows for automated or semi-automated production process or fill stations.

- Air Powered Feeders
- Electromechanical Feeders
- Volumetric Feeders
- Tube Feeders

Other Vibratory Equipment

VIBRATORY TABLES

Handle tough material challenges of condensing, settling, densifying, de-airing and packing and built to fit your needs in production, filling and packing or weighing.

- Light-Duty Packers
- Jogger Tables
- Shake-Out Tables
- Specialty Systems
- Flat Deck Tables
- Grid Top Tables
- Weigh-Scale Packers
- Vibratory Conveyor Systems



**Model FA
Flat Deck**

Our most popular Vibratory Table option, Model FA is typically used to settle material in cartons, drums, kegs, boxes and bags or for removing air from poured concrete and refractories.

**Model WFT
Weigh Scale Flat Deck**

Weigh Scale Packers allow for filling, weighing, and vibration of bulk containers. Tables can be fitted with digital scale instruments that incorporate set points to control the start and stop of the fill device, as well as the vibration sequence.

**Weigh Scales are available in a variety of deck options to meet any requirements.*

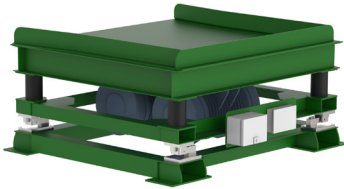

**Model VP
Light Duty Tables**

Commonly used for compacting coffee, pharmaceuticals, or other powdered products in small containers such as bottle, cans or bags. Force and frequency of Air Powered Models are adjustable by air pressure regulation, while electric tables are adjustable by mechanical means or an optional (VFC) Variable Frequency Controller.

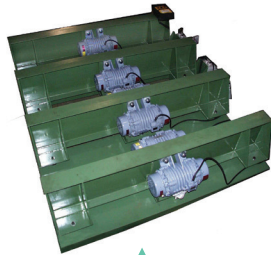

Live Beam Vibratory Table Model

Built primarily for the consolidation of concrete or castable materials in large forms and moulds. Ideally suited for pre-stressed concrete forms, the beams can be spaced apart as much as 10 to 15 feet for handling long and narrow, yet extremely heavy loads.

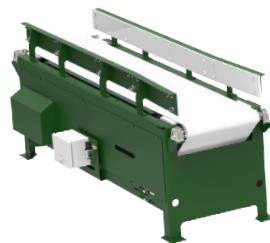

**Model BT
Belt Conveyor**

The Belt Table Conveyor is designed to simultaneously settle product within its container while transporting the container to a closing and sealing machine. Linear vibration aids in settling the material in its container before the container is closed.

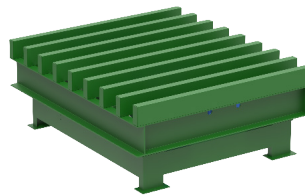

**Model GT
Grip Top**

Ideal for automatic and semi-automatic packaging and filling lines that use roller conveyor systems. The table is installed at the filling or compaction station of an in-line conveyor system. GT Grid Top Tables are available in standard, low profile or custom configurations.

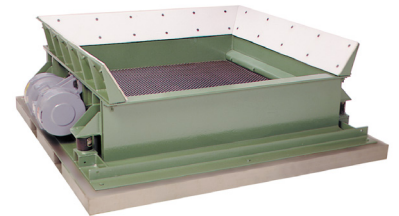

**Foundry
Shake-Out**

Shake-Out Tables feature a low profile design and quiet operation, with no noise generated from the steel isolation springs, belts, pulleys, or vibrating crank arms of other designs. Units with UHMW coated side deflectors are available. Able to handle loads up to 12,000 lbs. depending on deck size.

Drum Packer Model

Eliminate dead space in large drums before shipping, reducing container costs. Common applications include compacting granules, powders, pellets, molded or stamped rubber, plastics and steel parts. It's rugged yet compact design takes up less than 6 square feet of floor space and is rated for continuous duty. Air Powered and Electric Powered options available. Meets OSHA Noise Requirements.

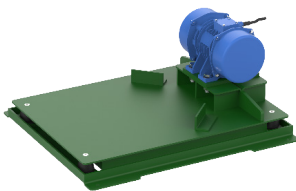

**Model VJ
Electromagnetic
Vibratory Jogger**

Ideal for filling small moulds in the plastic and fuse industries, it has also been used in the chocolate and candy industry. This rugged unit comes with a HDPE (High Density Polyethylene) deck and built-in controls. The unit is designed for 115/1/60 operation and the frequency is fixed at 3600 VPM.



FOR MORE INFORMATION

Call: Sales at 800-221-3298

Email: sales@clevelandvibrator.com

Buy Online: www.clevelandvibrator.com

